

STAINLESS STEEL 316L PRESS FIT FITTINGS (M PROFILE)

COMPLY WITH BSEN1254-2: 1998

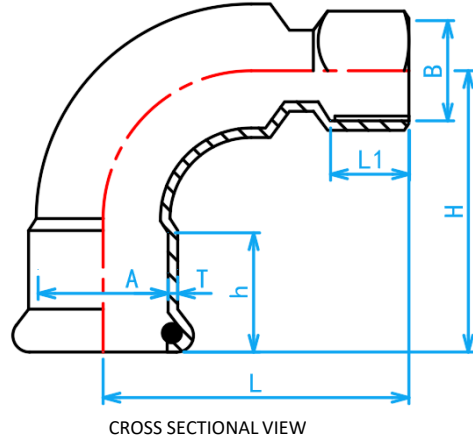

FI 90° ELBOW



DIMENSIONS

SKU	A × B (mm × inch)	L (mm)	H (mm)	h (mm)	L1 (mm)	T (mm)	WEIGHT (kg)	PCS/CTN
SS316LFIE01515	15 × 1/2" BSP	43	43	20	15.5	1.5	0.060	300
SS316LFIE02015	22 × 1/2" BSP	43	50	21	15.5	1.5	0.078	160
SS316LFIE02020	22 × 3/4" BSP	48	50	21	16.0	1.5	0.090	160
SS316LFIE02515*	28 × 1/2" BSP	68	60	23	15.5	1.5	0.115	160
SS316LFIE02520*	28 × 3/4" BSP	55	60	23	16.0	1.5	0.128	80
SS316LFIE02525	28 × 1" BSP	62	60	23	20.0	1.5	0.146	70
SS316LFIE03515	35 × 1/2" BSP	76	72	26	15.5	1.5	0.165	60
SS316LFIE03520*	35 × 3/4" BSP	76	72	26	16.0	1.5	0.170	60
SS316LFIE03525	35 × 1" BSP	65	72	26	20.0	1.5	0.195	60
SS316LFIE03525L	35 × 1" BSP	80	90	26	20.0	1.5	0.230	40
SS316LFIE03535	35 × 1 1/4" BSP	68	72	26	22.0	1.5	0.235	80
SS316LFIE04215*	42 × 1/2" BSP	86	85	31	15.5	1.5	0.165	30
SS316LFIE04220*	42 × 3/4" BSP	83	85	31	16.0	1.5	0.233	30
SS316LFIE04225*	42 × 1" BSP	90	85	31	20.0	1.5	0.260	30
SS316LFIE04235*	42 × 1 1/4" BSP	98	85	31	22.0	1.5	0.278	30
SS316LFIE04242	42 × 1 1/2" BSP	80	85	31	25.0	1.5	0.300	30
SS316LFIE05015*	54 × 1/2" BSP	97	105	35	15.5	1.5	0.337	21
SS316LFIE05020*	54 × 3/4" BSP	100	105	35	20.0	1.5	0.345	25
SS316LFIE05025*	54 × 1" BSP	102	105	35	22.0	1.5	0.378	25
SS316LFIE05035	54 × 1 1/4" BSP	106	105	35	24.0	1.5	0.403	25
SS316LFIE05042*	54 × 1 1/2" BSP	100	105	35	25.0	1.5	0.396	25
SS316LFIE05050	54 × 2" BSP	93	105	36	25.0	1.5	0.460	30
SS316LFIE06565	67 × 2 1/2" BSP	133	143	50	28.0	1.8	0.970	15

*This item requires special ordering. Please consult with a salesperson for the estimated lead time.